

## **Farm-Scale Food Dehydrator**

Allen Dong, PO Box 413, Veneta, OR 97487

[www.efn.org/~itech/](http://www.efn.org/~itech/)

Public Domain--a gift to humanity. (updated 11/2009, 1/2003, original 11/1998)

This food dehydrator design is a scale-down variation of the "Community Dehydrator" (R.I. Guillou and B.D. Moses. July 1943. Farm Building Plan C-216. Agricultural Engineering Extension, University of California, Davis, CA 95616). The drying chamber holds eight 3x3 feet trays, with 3 inch spacing between trays. A 20-inch box fan is positioned adjacent to the trays. The fan draws heated air from the upper level and blows it across the trays. A shroud surrounds the fan to assist in directing the air across the trays. The vent door regulates air exhaust and recirculation to the upper level. Heat is provided by a 1500 watt, thermostatically controlled space heater located in the upper level above the drying trays. The exterior wall is made of 1/2-inch plywood, the interior wall is 1/2-inch drywall and the frame is 2x2 and 2x4 inch lumber. The wall cavity is insulated with polystyrene insulation.

During the initial drying stage, the vent door is opened wide. After the removal of free surface water (about 30 minutes), the vent door is closed in stages to increase the recirculation of heated air. The relative humidity in the cabinet is maintained below 50% and the dry bulb temperature below 140 F. If the ambient air is sufficiently dry, the dehydrator can be operated without additional heat input with the vent door wide open.

In this design, the fan is placed in the lower level, adjacent to the drying trays to improve the uniformity of airflow across the trays, top to bottom and side to side. In contrast the "Community Dehydrator" fan is located in the upper level resulting in a decrease in the uniformity of airflow as the air current turns 180 degrees and flows in the opposite direction in the lower level. The fan placement of the Community Dehydrator permits free movement of the drying carts through the lower level without fan obstruction, thus scaling up to a tunnel dryer.

Additional information (1/2003):

Heat requirement:

The UC Davis Community Dehydrator uses a 60,000 Btu per hour burner for continuous operation on 187 square foot drying tray area; or 321 Btu per hour per square foot of drying area; or 94 watt per square foot of drying area. For batch operation, the Community Dehydrator uses a 120,000 Btu per hour burner, or 641 Btu per hour per square food of drying area, or 188 watts per square food of drying area.

Dale E. Kirk's home size dehydrator (USDA Home and Garden Bulletin 217) uses nine 75-watt light bulbs as heater for 8.5 square feet of drying area or 79 watts per square foot of drying area.

The Farm-Scale Food Dehydrator describe here uses a 1500-watt heater on 72 square feet of drying tray area or 21 watts per square foot of drying area. The lower temperature output of the heater results in a longer drying time. It is partly compensated by the higher air flow rate. If more heat is required, use suitable propane burner.

**Airflow rate:**

The UC Davis Community Dehydrator uses a 4500 cubic feet per minute fan, equivalent to 6.1 volume of air exchange per minute.

The 20-inch box fan used in the I-Tech Farm-Scale Dehydrator circulates 2100 cubic feet per minute in free space. If the tray resistance reduces the airflow by half, this equates to 58 volume of air exchange per minute.

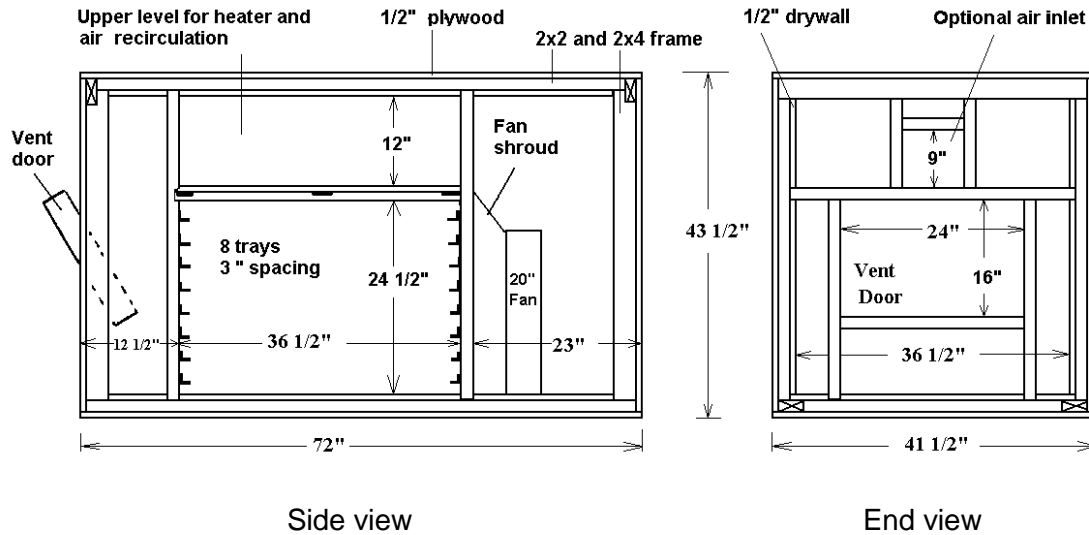
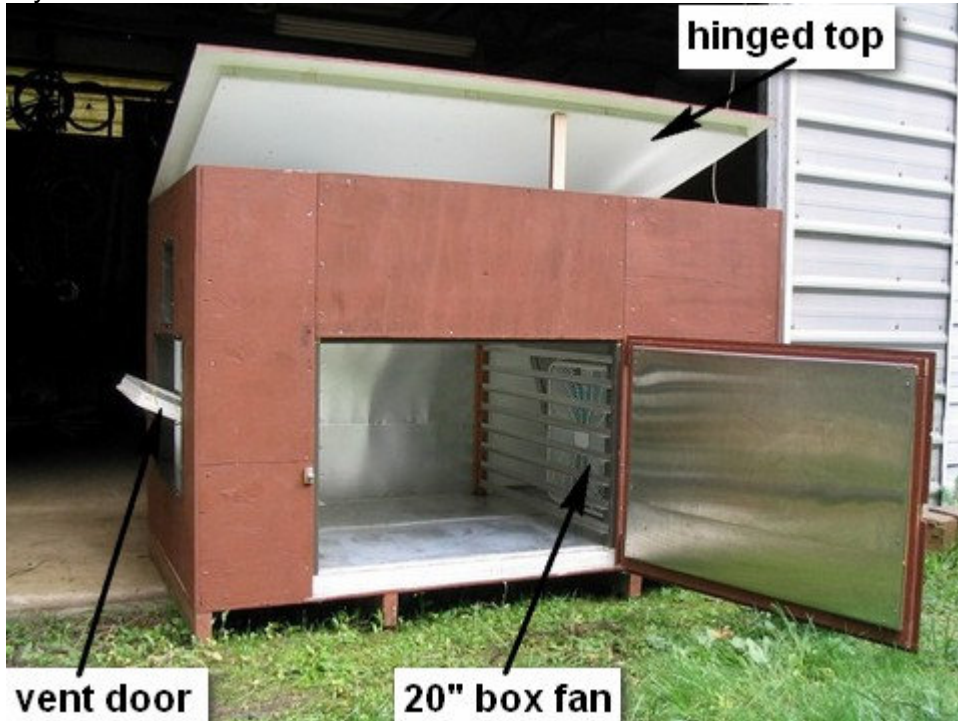

Figure 1. Food Dehydrator using 1/2 inch plywood, 2x2 and 2x4 frame and 1/2 inch drywall.



Dehydrator components.

Frame 2x4 and 2x2 lumber, refer to Figure 2.

- A. Bottom frame, 2x4, 2 pieces 71" (72" – 1" for plywood thickness)
- B. Bottom frame, 2x4, 2 pieces 33 ½" (41 ½" – 1" for plywood thickness –7" for 2x4)
- C. End uprights, 2 x 4, 4 pieces 39 ½" (43 ½" – 1" plywood thickness, - 1 ½" bottom 2x4, - 1 ½" top 2x2), cut notch at top
- D. Top frame, 2x2, 2 pieces 68" (72" – 1" for plywood thickness –3" for 2x4)
- E. Top frame, 2x4, 2 pieces 40 ½" (41 ½" – 1" for ply wood thickness)
- F. Opening for door, 2x2, 2 pieces 39 ½". Notch the 2 sidepieces to fit header.  
These sidepieces provide support for attaching the drywall, drywall divider separating upper chamber from lower drying area, and support for mounting drying tray bracket. F', 2 pieces, located in the back wall provide support for attaching drywall, drywall divider, and support for wood to mount drying tray bracket. F'', 3 pieces (only one shown in Figure 2) located at end provide support for attaching drywall.
- G. Opening for door, header, 2x2, 1 piece 37".
- H. Vent door opening, side support, 2x2, 2 pieces, 28"
- I. Vent door opening, bottom, 2x2, 1 piece, 24"
- J. Vent door opening, top, 2x2, 1 piece, 37 ½"

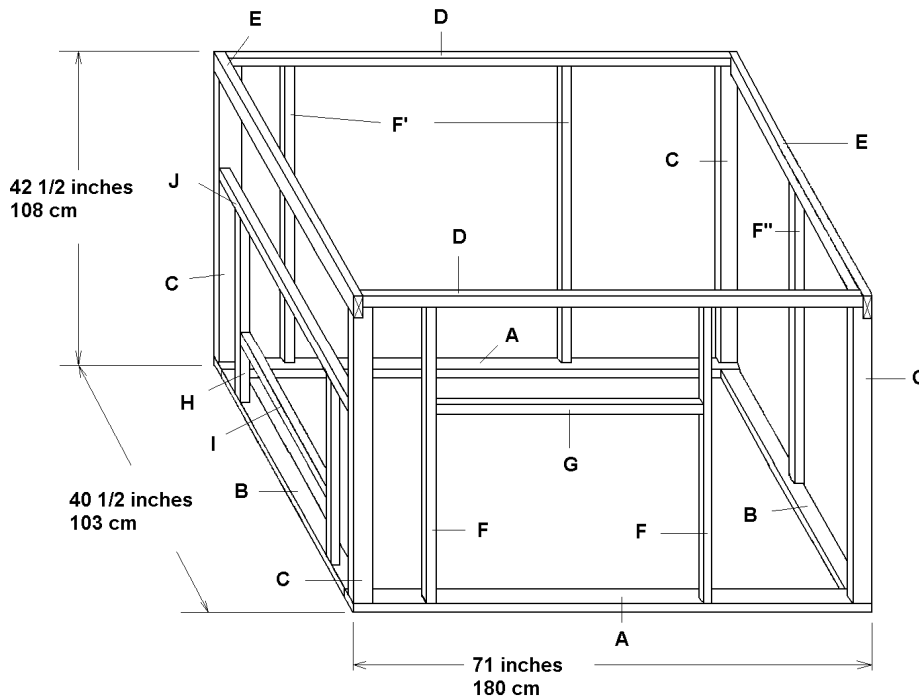

Figure 2. Dehydrator frame shown without ½ inch plywood outer shell, cavity insulation and ½ inch interior drywall.

Not shown in Figure 2: Half-inch plywood outer shell; 2x2 miscellaneous lengths around the bottom for attaching drywall; and optional gas heater opening.