

DIY: Build your own hand operated screen seed cleaner

Allen Dong, I-Tech, PO Box 413, Veneta, OR 97487

www.efn.org/~itech/

Public domain, no copyright, a gift to humanity (March 2014)

Introduction

This hand operated screen seed cleaner separates seeds from chaff by sifting. Seed and smaller materials drop through the screen into a tote bin below. Larger chaff (leaves, stems, pods and debris) retained by the screen discharge over the edge of the screen, outside the tote bin. It does not use a motor or engine, and does not have a feed hopper, air separator or elevated frame.

Compared to hand held screen sifting, the advantage of this screen seed cleaner is the use of 4 springs. Without the springs, much effort is consumed in changing the screen's direction of motion. A force is applied to accelerate the screen in the forward direction, then a counter force is applied to halt the forward motion and propel the screen in the opposite direction. At the end of the reverse direction, a force is again applied to halt and change the direction of motion. Instead of applying external force to change the direction of motion throughout the oscillation cycle, springs are used to perform the same task. External force is applied to overcome frictional losses.

The design is robust; it can be made larger or smaller depending on size of tote bin.



Figure 1. Manually operated screen seed cleaner

Description

The screen seed cleaner has a cradle which holds 1 or 2 screens (Figure 1 and 2); a frame to support the horizontally oscillating cradle and screen while sifting seeds from chaff (Figure 1, 3 and 4); 4 wire springs to conserve mechanical energy of the oscillating cradle (Figure 5); and optional bronze sleeve bearings to reduce friction at the pivots.

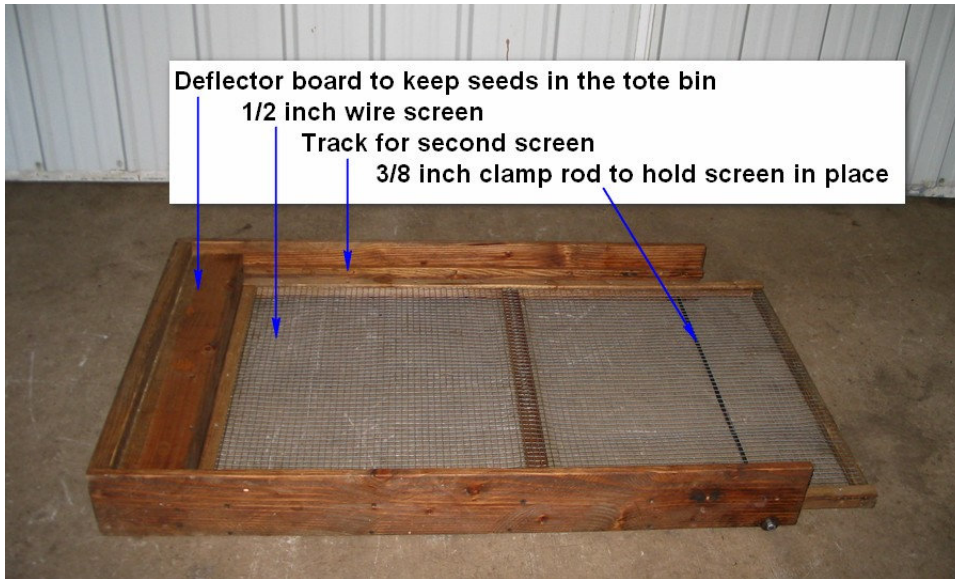

Figure 2. Cradle with 1/2 inch wire screen



Figure 3. Frame with chains to adjust spring tension.

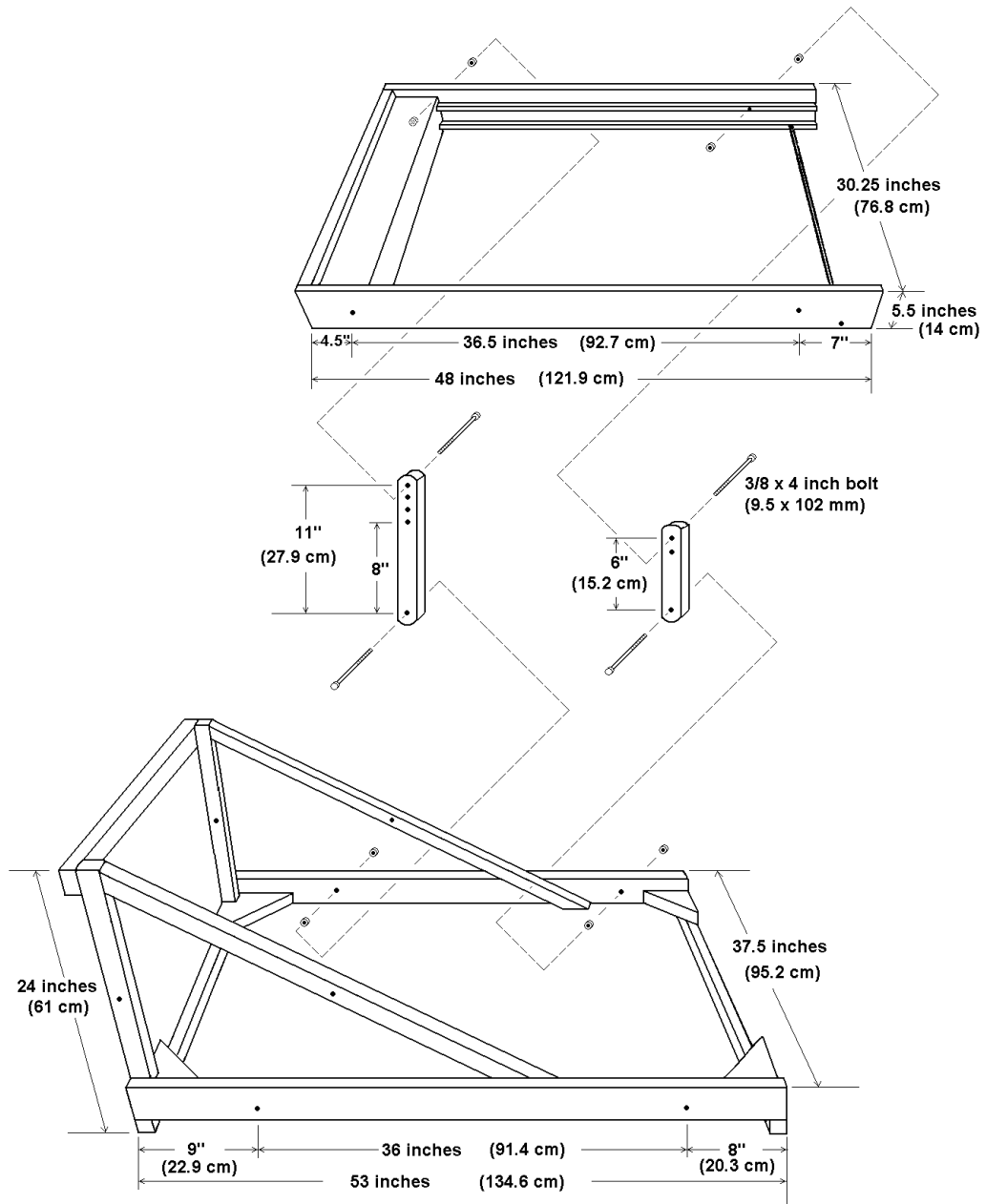

Figure 4. Hand operated screen seed cleaner, exploded diagram. Extension springs, chains and optional bronze sleeve bearings not shown.

Dimensions: designed to sit on top of a 4 x 4 foot tote bin (Figure 6)

1. Cradle dimensions: 5 ½ " tall x 30 ¼" wide x 48" long (14 x 77 x 122 cm). It clamps the screen in position with a 3/8 inch (9.5 mm) rod and discharges larger material outside the tote bin.
2. Frame length = 53 inches (135 cm), overhangs the tote bin.
3. Frame width = 37 ½ inches (95 cm), narrower than the tote bin, to capture materials passing through the screen.
4. Extension springs: 15.5 pounds per inch load rate; 0.125" wire diameter x 1.075" outside diameter x 3.875" body length x 5.5 inch overall length (3.2mm wire x 27.3 mm diameter x 98 mm body length x 140 mm length). The springs provide a 2 inch (5 cm) oscillation when sifting 40 pounds (18 kg) of seed in the 24 pound (11 kg) cradle with screen. Extension springs are available at "Amazon"; springs with larger dimensions are preferred (wire diameter, outside diameter and length). For equivalent material composition and load rate, a spring with larger dimensions tolerates more stress and have lower fatigue failure rate.
5. Screen slope: adjustable, 0.08 to 0.17. Steeper slope is used when scalping off large chaff; otherwise chaff will pile up on the screen. Shallower slope is used on subsequent re-screening or with smaller material.
6. Construction materials: mostly 2x4s, 2x2 cut from 2x4s; 1x6 cut from 2x6

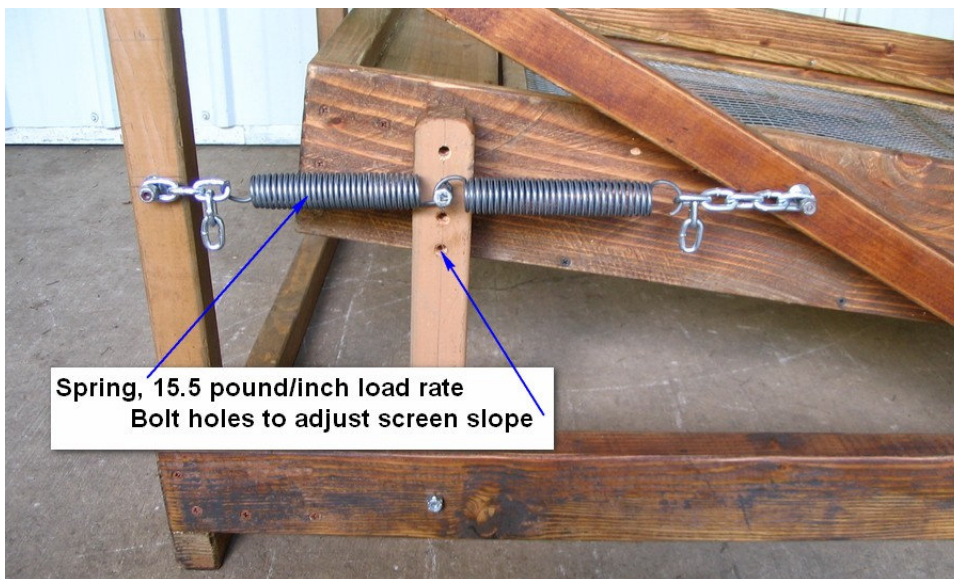

Figure 5. Extension springs, close-up. Strut with 4 bolt holes adjusts the slope of the cradle with screen.



Figure 6. Hand operated screen seed cleaner elevated on a tote bin to collect seeds that pass through the screen.

References

Engine driven screen seed cleaner designs that were examined while building this hand operated screen seed cleaner:

1. Clipper 109A. AT Ferrell, Saginaw, MI; Bluffton, IN.
2. Hance Model 36 Super Speed Scalper. The Hance Corporation, Westerville, Ohio.
3. IRRI Portable Grain Cleaner GC7. The International Rice Research Institute, Manila, Philippines.

Technical assistance:

Larry Fisher, Totally Recycled Materials, Davis California